

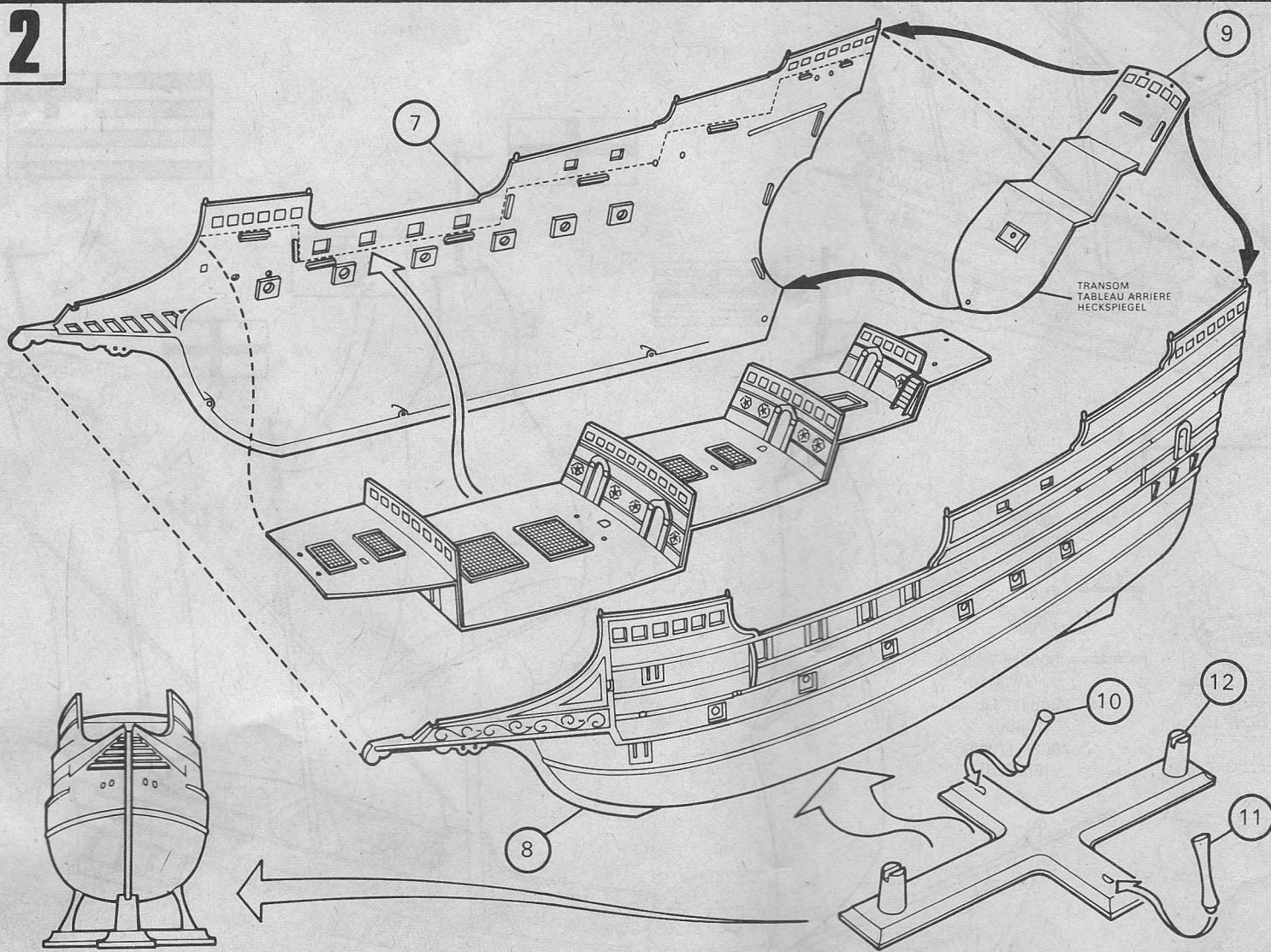

SCALE MODEL OF FAMOUS OLD WARSHIP

THE REVENGE

The Revenge, a typical Elizabethan Galleon, was launched in 1577. She was 92 feet long in the keel, 32 feet in breadth and carried 34 carriage and 12 swivel guns. Her design shows much improvement over earlier vessels with particularly fine underwater lines and much lower stern works than the early Tudor vessels, although the four masted rig, normal for that period, was not particularly efficient. The Elizabethan men-of-war were the outstanding ships of the time and were designed to fight with long gunfire rather than by boarding tactics. They were extremely manoeuvrable by virtue of their short keel and long overhand; a virtue that was to be well employed against the Spanish Armada. On June 19th 1588, news reached Plymouth that the Spanish Armada had been sighted in the channel and Sir Francis Drake, who legend has it, was playing bowls at the time, set out with the English fleet and his flagship the Revenge. The Armada consisted of 129 vessels against the English fleet of 80, only 39 of which were ships of the line. The English fleet attacked the Armada with gun fire at a distance, refusing to come to close quarters and relying on their manoeuvrability to escape from the much larger Spanish Galleons. These hit and run tactics were successful and several of the enemy were sunk or driven ashore and the galleon Rosario captured by Drakes Revenge during the week of combat. On the 28th June, the Armada sought shelter in Calais and during the night, eight of the smaller English boats were filled with combustible material and set ablaze among the Spanish fleet; the Spanish cut their cables and stood out to sea. At dawn on the 29th June, the English came up with them at Gravelines and during the six hour battle which ensued 4,000 of the Spanish were lost for only 100 English casualties. The surviving vessels of the Armada tried to escape by sailing around the Orkneys but although the English were unable to pursue them a great storm completed the destruction, and of the 100 ships left only 54 returned to Spain. In 1661 the Revenge was again in action, this time commanded by Sir Richard Grenville. At Flores, the Revenge which was alone, was attacked by a fleet of fifteen Spanish galleons. The fight continued all day and the Revenge sunk two of the galleons and crippled two others before being forced to surrender. Three days later Sir Richard Grenville died from wounds sustained during the battle and the Revenge did not long survive him, sinking in a storm while being taken back to Spain as a prize.

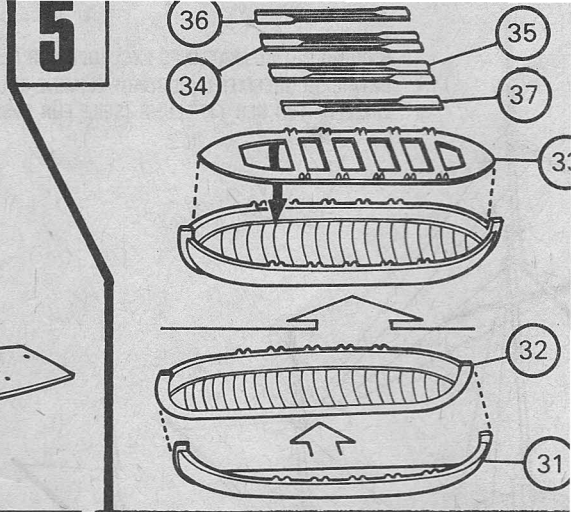
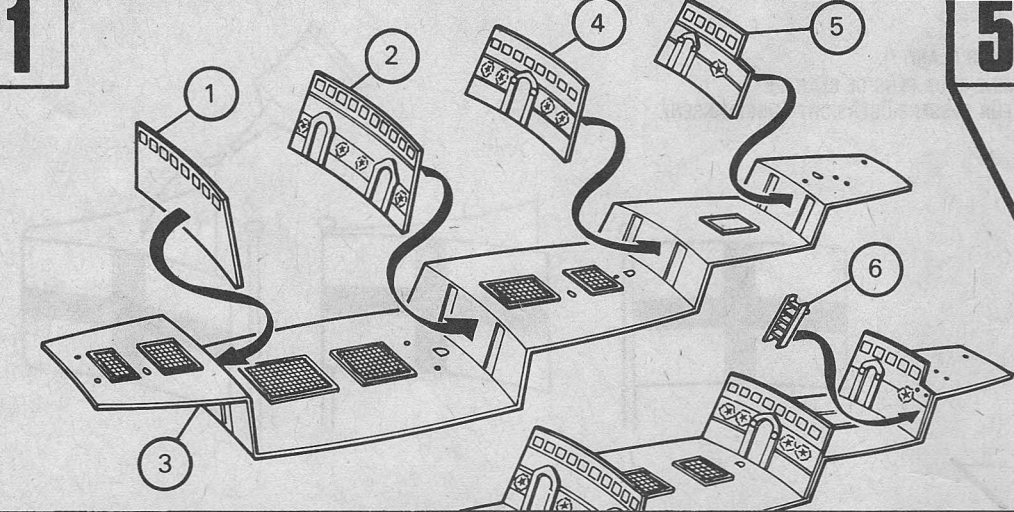

3

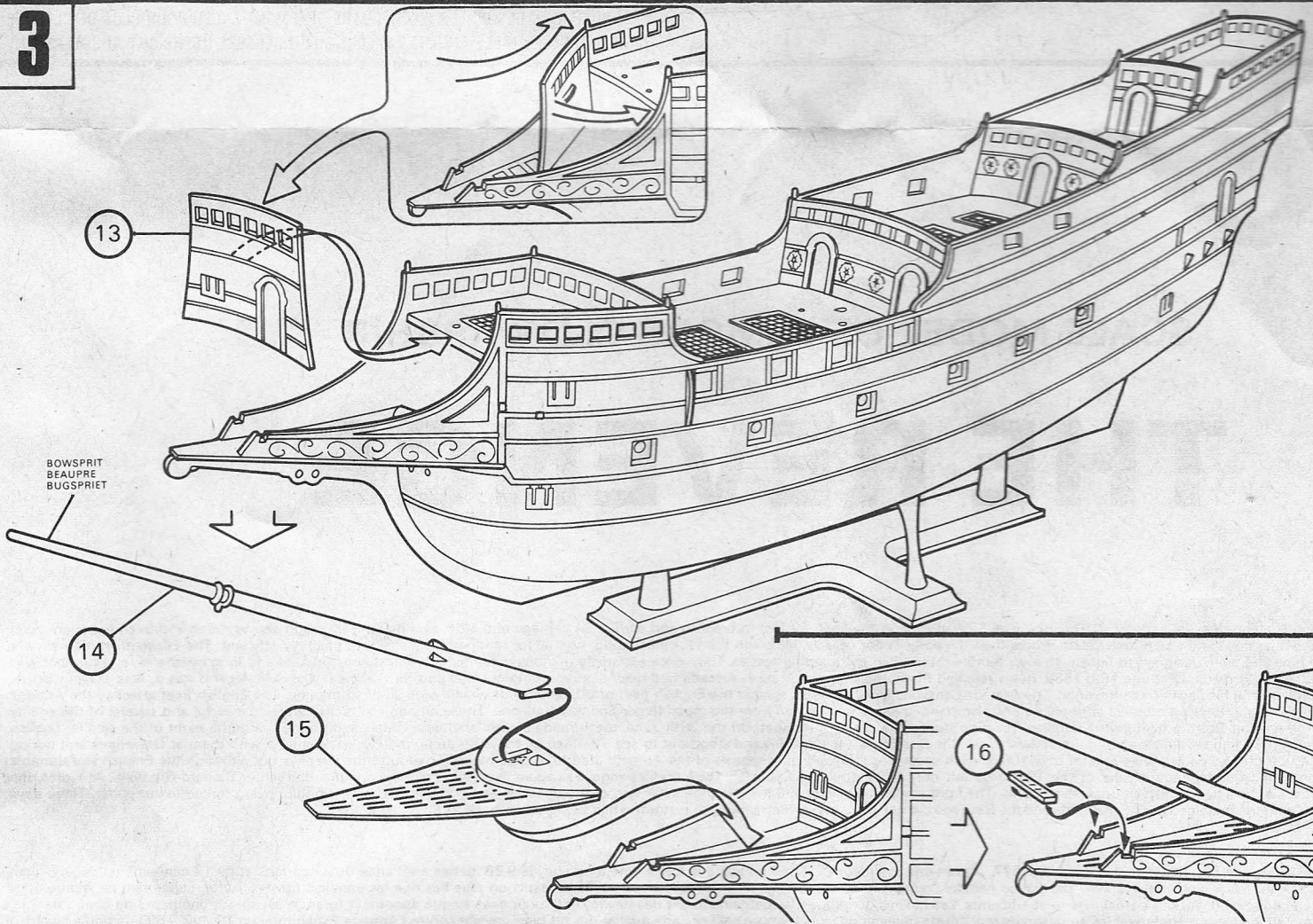

BOWSPRIT
BEAUPRE
BUGSPRIET

14

15

16

4

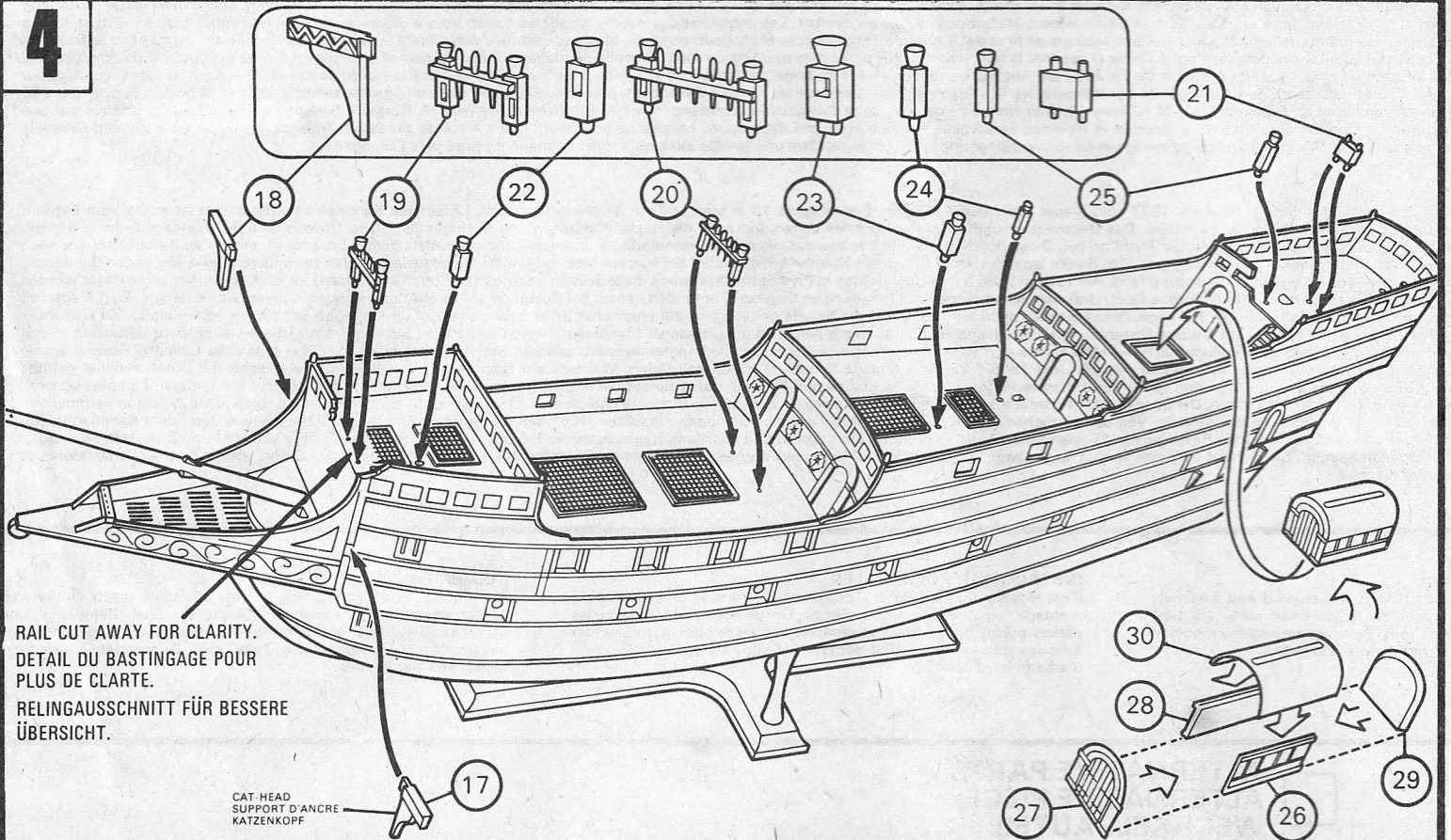

RAIL CUT AWAY FOR CLARITY.
 DETAIL DU BASTINGAGE POUR
 PLUS DE CLARTE.
 RELINGAUSSCHNITT FÜR BESSERE
 ÜBERSICHT.

CAT HEAD
 SUPPORT D'ANCRE
 KATZENKOPF

17

30

28

27

26

29

21

18

19

22

20

23

24

25

FOR COV
POU
AJU
FÜR AUS
SEIT

1

T
G
V

5

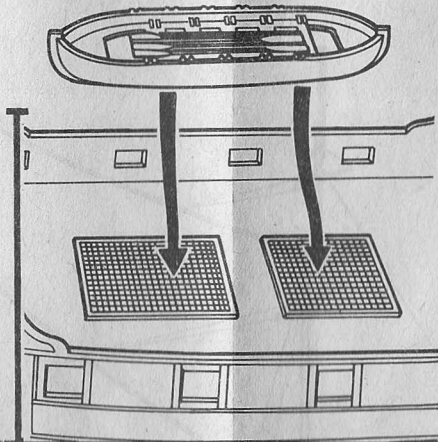
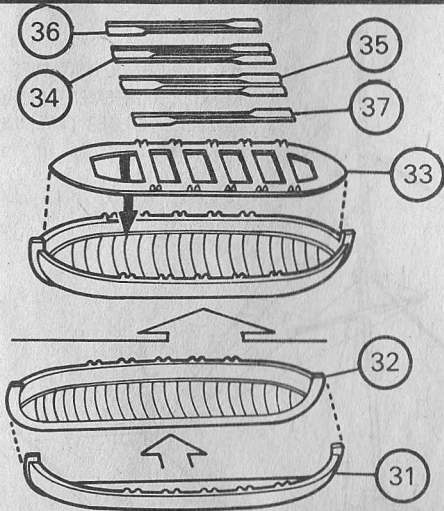

3

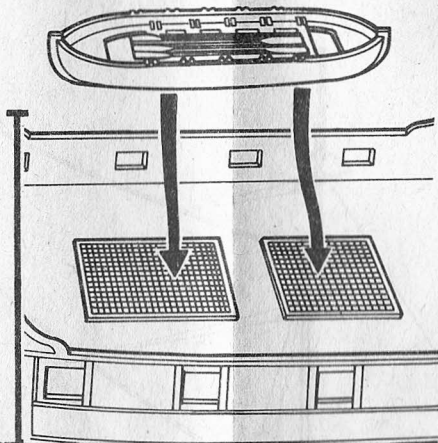

6

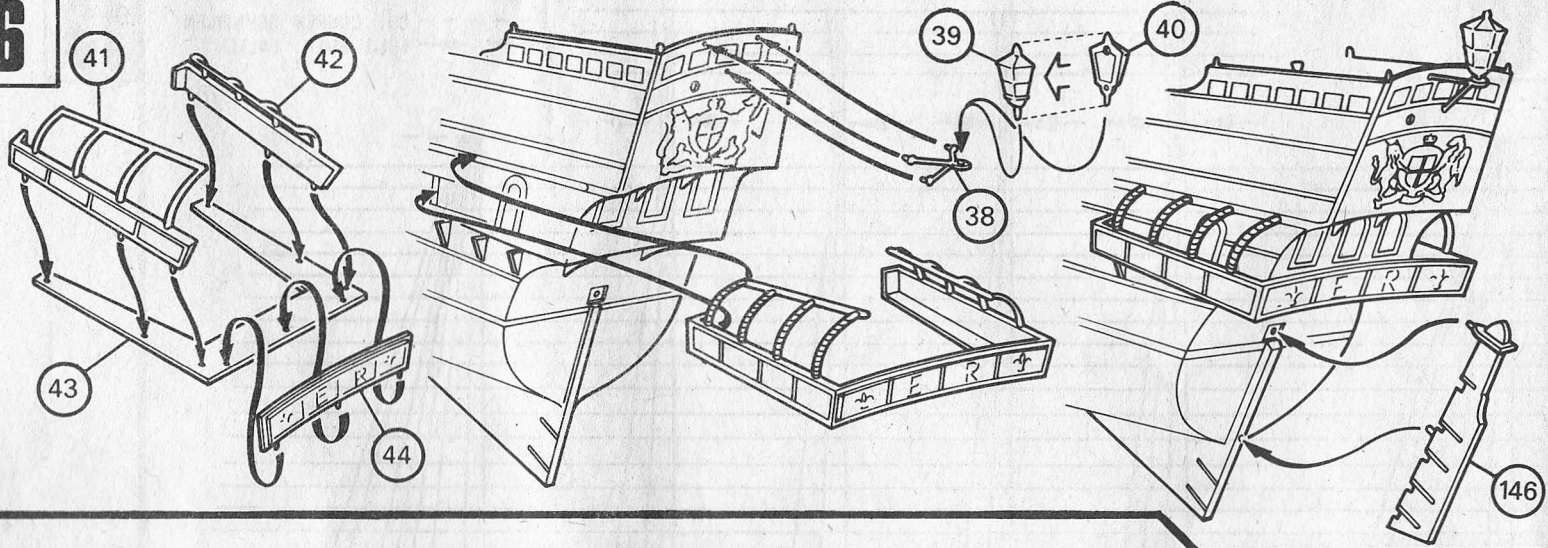

7

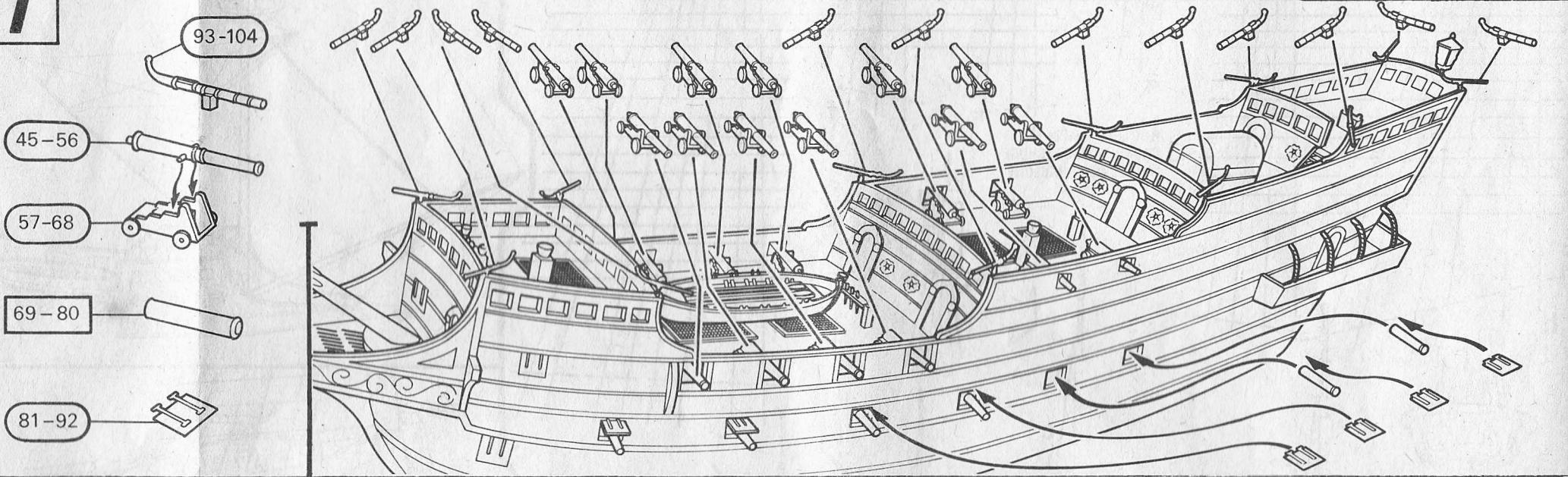

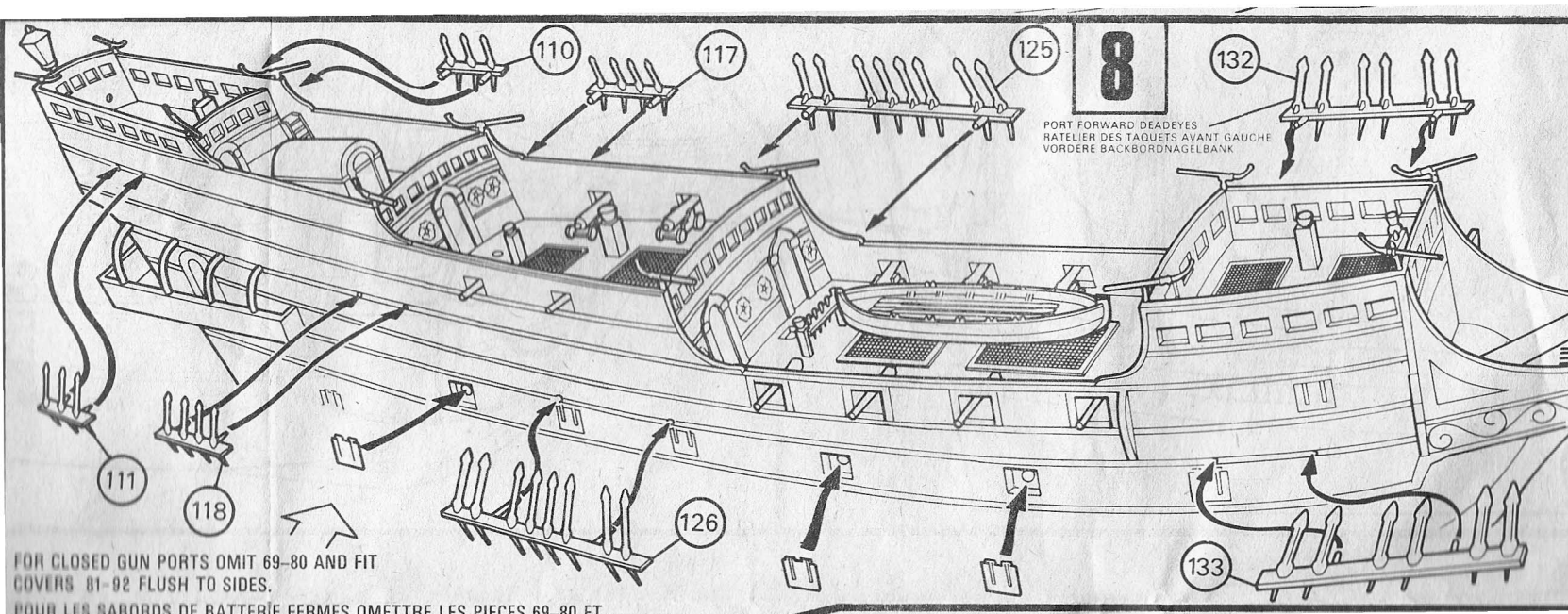

FOR CLOSED GUN PORTS OMIT 69-80 AND FIT
COVERS 81-92 FLUSH TO SIDES.
POUR LES SABORDS DE BATTERIE FERMES OMETTRE LES PIÉCES 69-80 ET

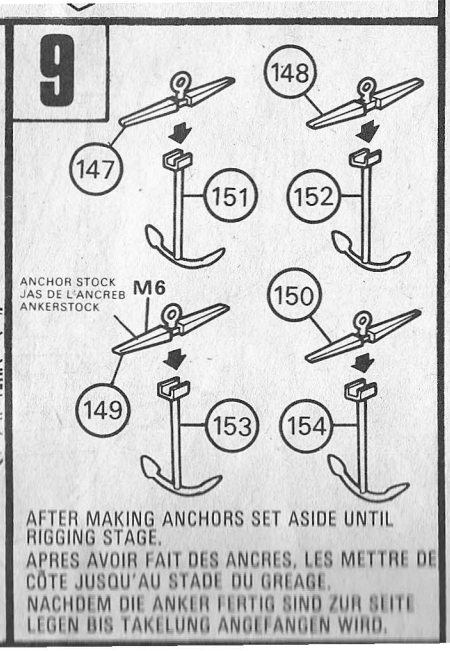

AFTER MAKING ANCHORS SET ASIDE UNTIL
RIGGING STAGE.
APRES AVOIR FAIT DES ANCRÉS, LES METTRE DE
CÔTÉ JUSQU'AU STADE DU GREAGE.
NACHDEM DIE ANKER FERTIG SIND ZUR SEITE
LEGEN BIS TAKELUNG ANGEFANGEN WIRD.

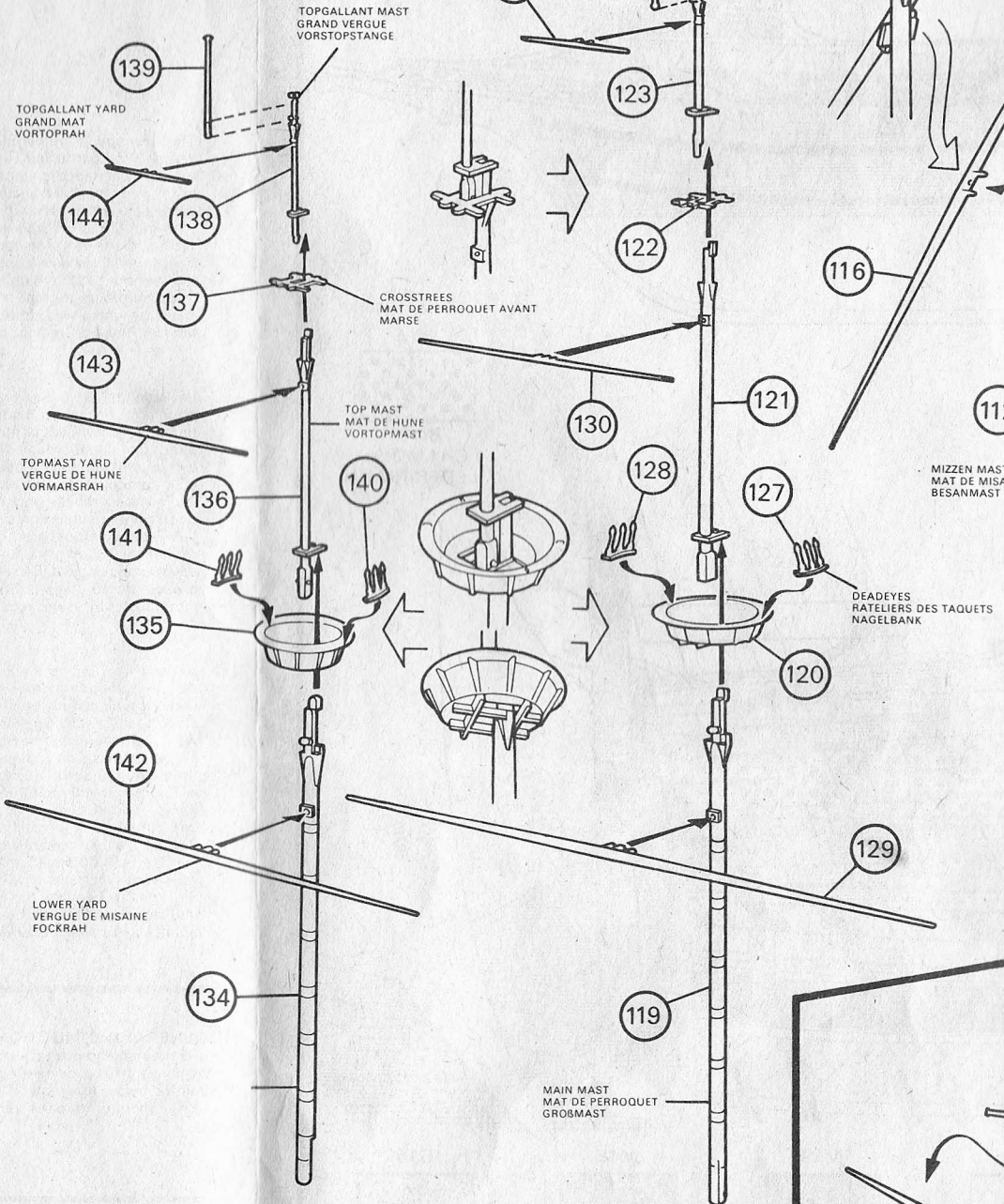

11

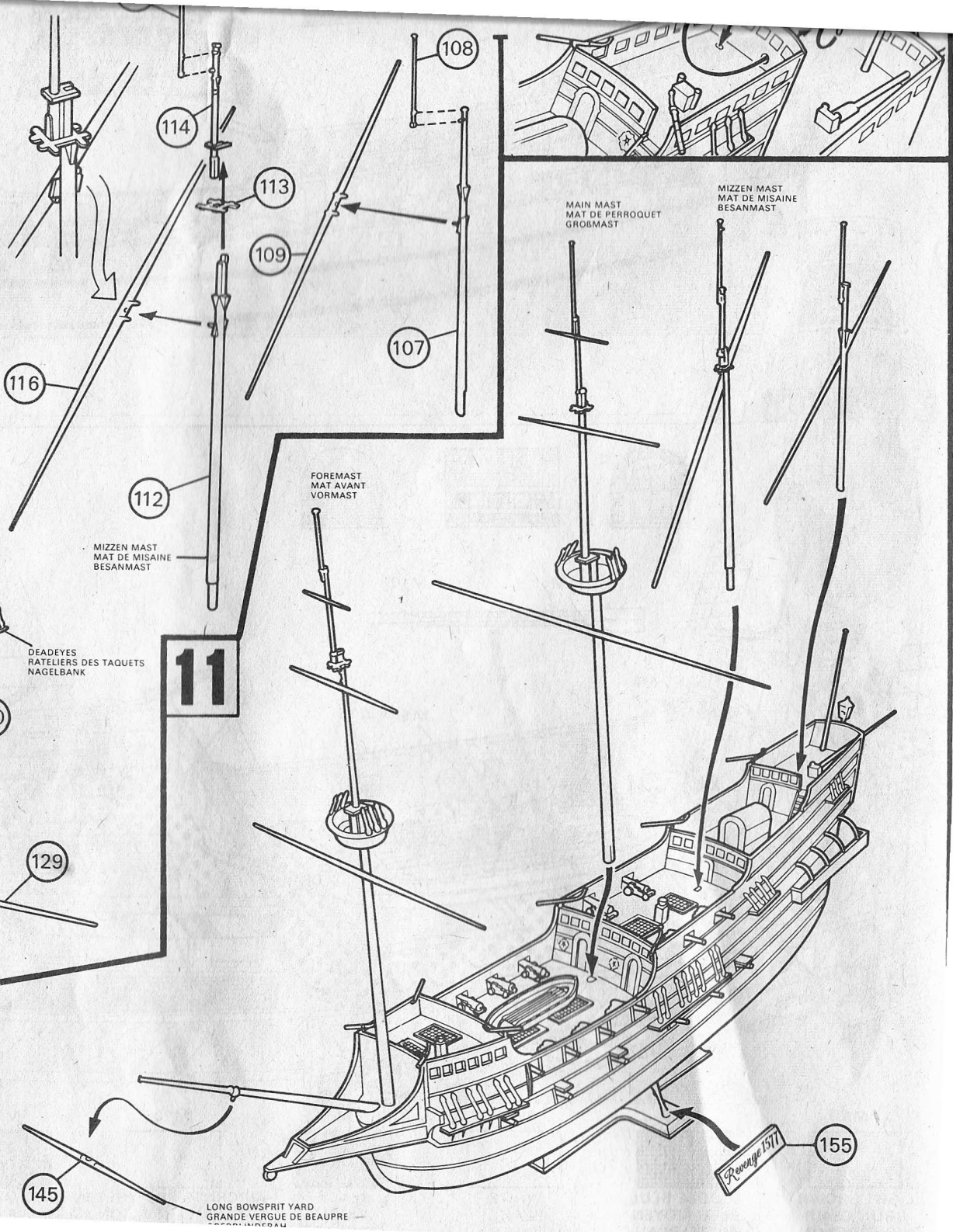

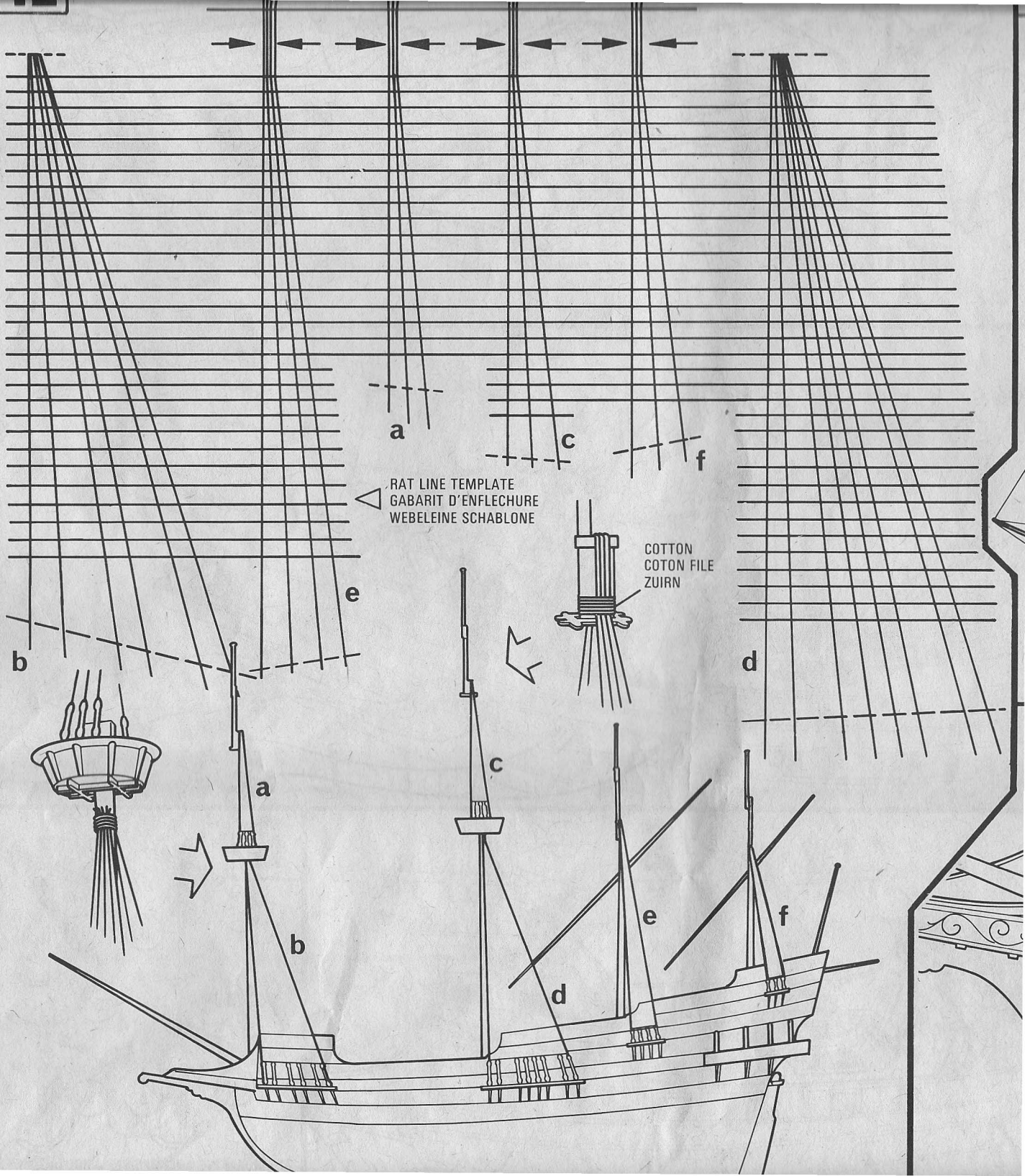

RIGGING DETAIL (RATLINES EXCLUDED FOR CLARITY).
 DETAIL DU GREEMENT (CORDAGE ELIMINE POUR PLUS DE CLARTE).
 EINZELHEITEN DER TAKELUNG (SEILE FÜR BESSERE ÜBERSICHT AUSGELASSEN).

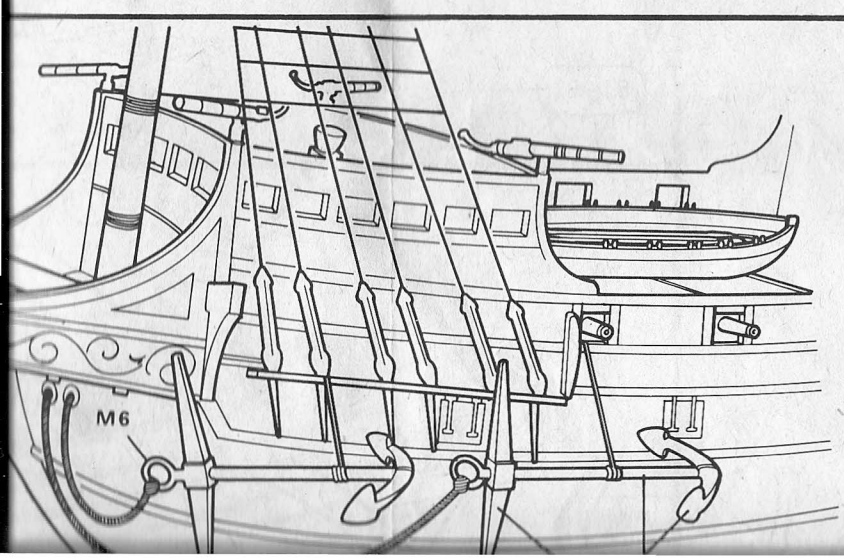
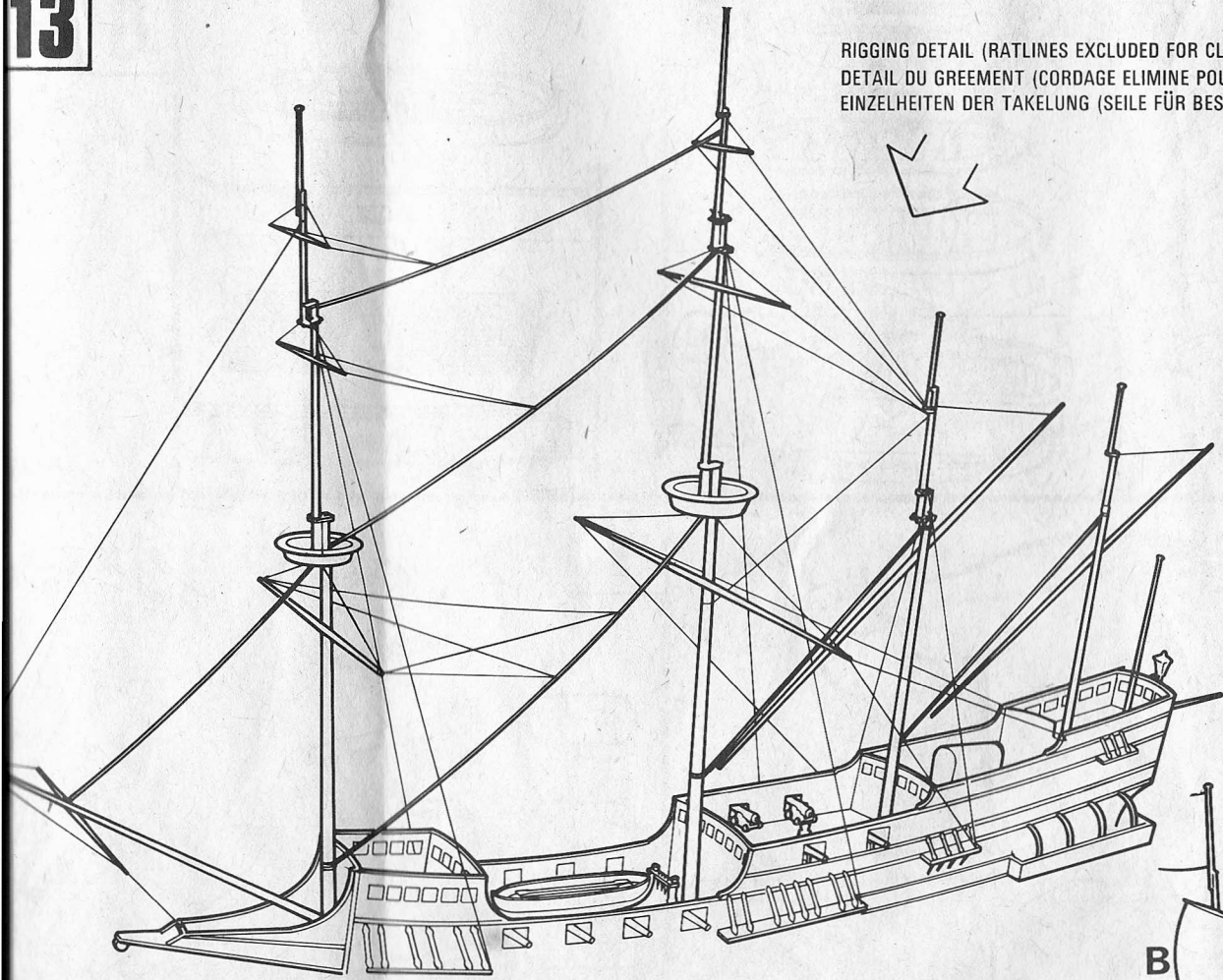

- COTTON.
COTON FILE.
ZUIRN.
- THREAD.
FIL.
ZWIERN.
- DOUBLE THREAD
(TWISTED).
DOUBLE FIL
(TORDU).
DOPPELZWIERN
(GEDREHT).

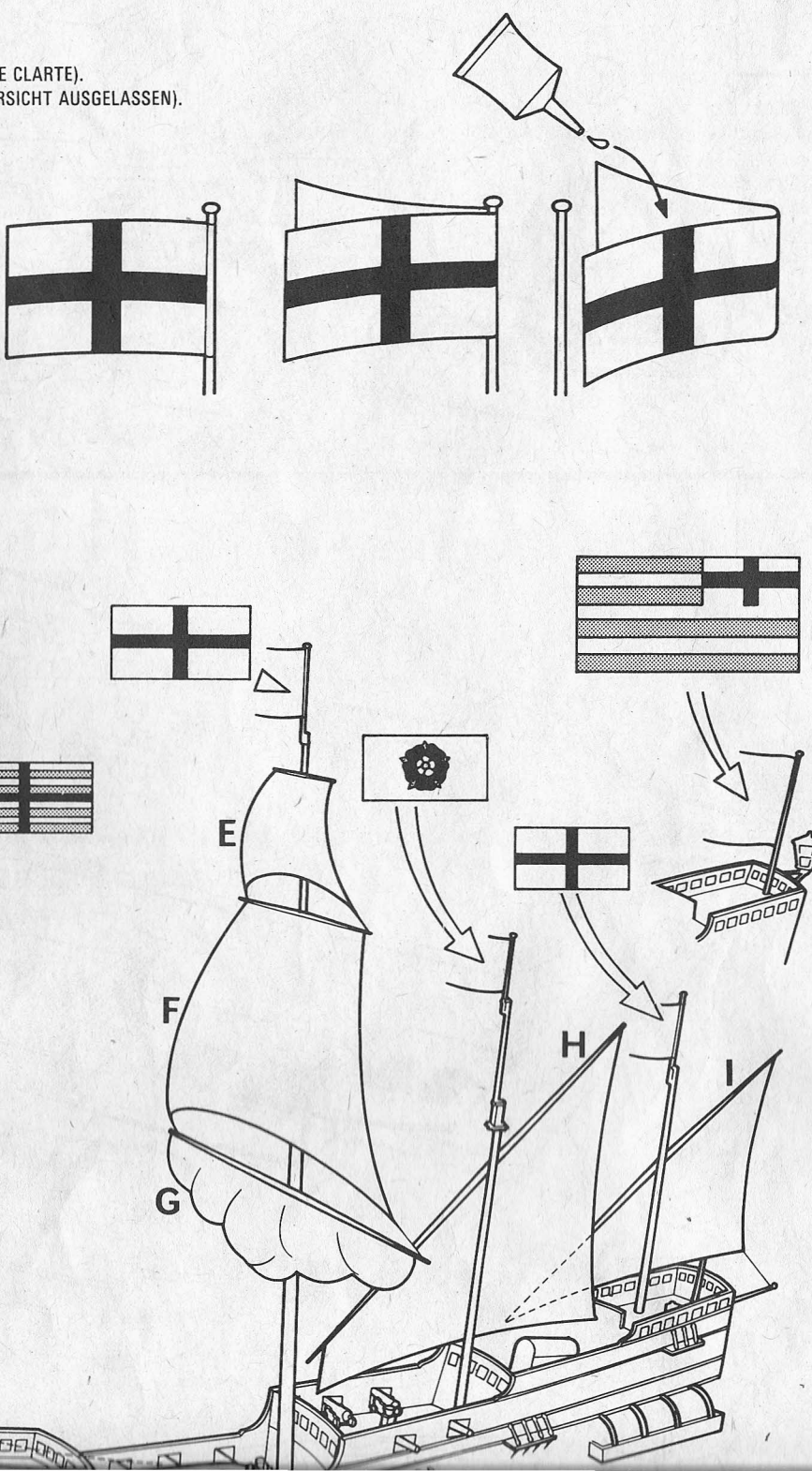
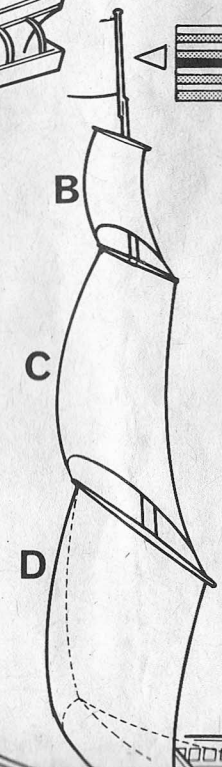

14

USE IN CONJUNCTION WITH BOX ARTWORK.
A UTILISER CONCURRENTMENT AVEC LA BOITE DE
TRAVAUX D'ART.
NACH VORLAGE AUF DER VERPACKUNG VERWENDEN.

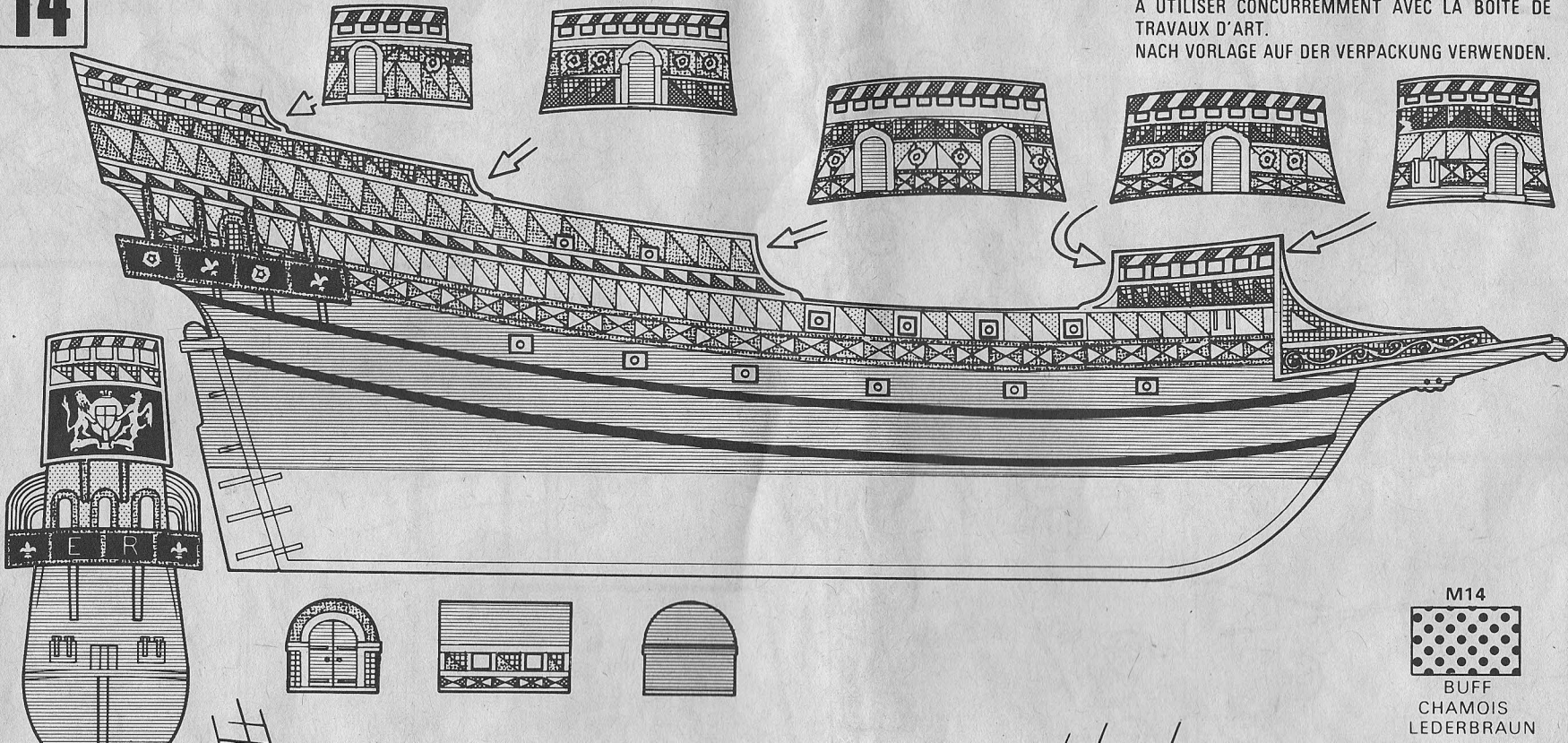

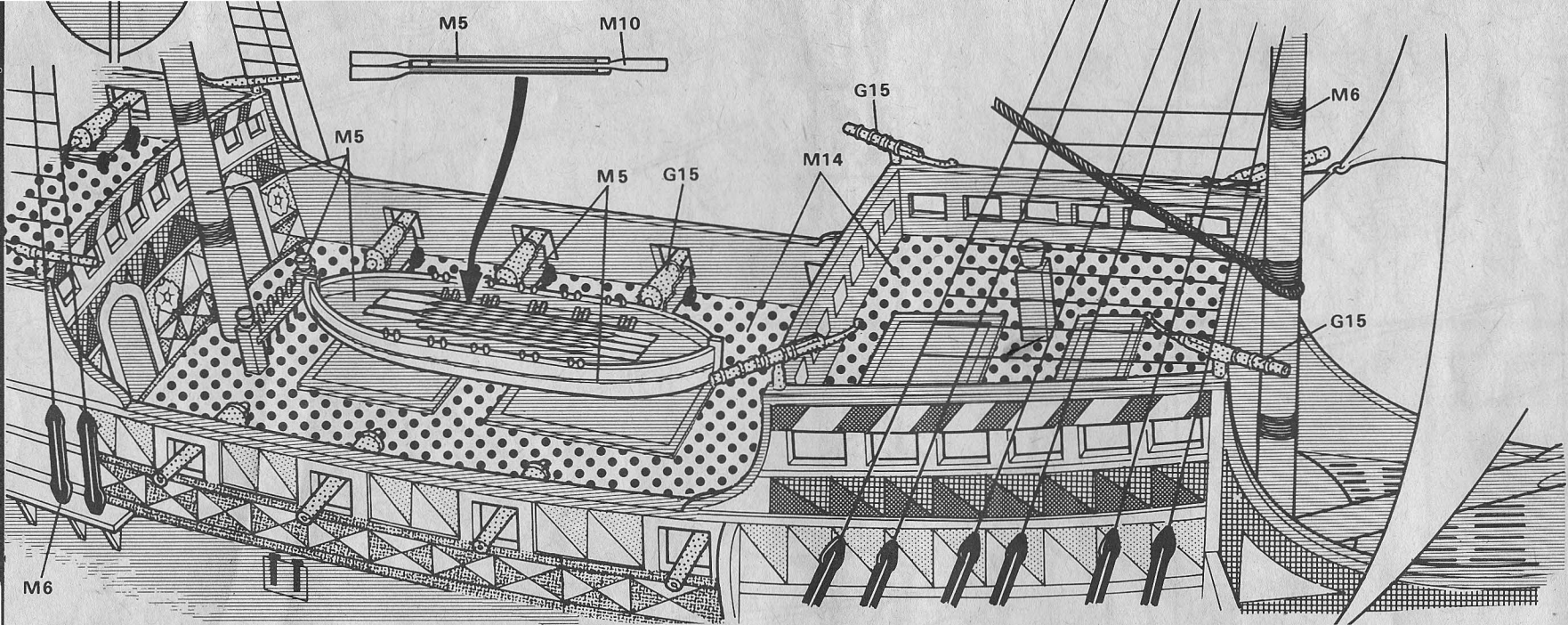

M5

 LIGHT BROWN
 BRUN CLAIR
 LICHT BRAUN

M11

 MIDDLE BLUE
 BLEU MOYEN
 MITTELBLAU

M10

 WHITE
 BLANC
 WEISS

M6

 BLACK
 NOIR
 SCHWARZ

M20

 AIRCRAFT GREY/GREEN
 GRIS/VERT AVION
 FLUGZEUGGRAU/GRÜN

M19

 SIGNAL RED
 ROUGE SIGNAL
 SIGNALROT

M15

 DEEP CREAM
 CREME FONCE
 MITTELCREMEGELB

G15

 BRONZE
 BRONZE
 BRONZE